

VIKING LLC (PRO 1000-6000) Pro Single Formula Laundry System

The Pro Laundry System is a single formula laundry system. It can pump one to six products in response to a trigger signal. The trigger inputs are isolated from each other but can be jumped together if a single common is available. Input trigger signal conditioning is provided. Maximum run time is approximately 3 ½ minutes per pump. Each pump produces 18 ounces per minute.

MOUNTING & POWER SUPPLY

For a unit with 1 - 3 pumps, mount the case using two screws. For a unit with 3 - 6 pumps, mount the case using all four screws provided. Make sure that the unit is within reach of a 110-volt outlet. Plug the unit in but do not turn it on at this point.

TRIGGERS

Make sure that power to the washing machine is turned off at the breaker before making any trigger connections. Always verify voltages with a voltmeter. Always run all trigger signals through conduit or seal tight from the washing machine to the dispenser.

There are three .250 quick disconnect tabs on each board for triggers. Each tab is marked. The Left-hand tab is always for the trigger. The two on the RIGHT are for the common, one for common and the other to jump to the next board if using a single common.

Use the quick disconnects and refer to the SILK SCREENING in order to hook up your triggers. Each circuit board will accept trigger signals of 24 - 240 volts AC or DC. They may be jumped together in order to dispense two products simultaneously. Do not run three pumps simultaneously. The triggers should only be present when the product is to be dispensed during the wash cycle - it should not activate the pump(s) at any other time.

The triggers must be present for at least 5 SECONDS to activate the pump. The small led in the center of the board will light when a valid trigger is present.



Installation of Viking products must meet all applicable electrical codes and regulations established by national, city, county, parish, provincial or other agencies. It is possible that electrical codes and regulations require that a certified electrical contractor or engineer perform the electrical installation. For questions, contact a certified electrician.



All installations must conform to local plumbing codes and use approved backflow prevention devices. pressure indicating tee is to be installed with existing faucets according to local plumbing codes in the state of Wisconsin and any other state that requires the use of a pressure indicating tee.



ALWAYS WEAR PROTECTIVE CLOTHING AND EYEWEAR WHEN WORKING WITH CHEMICAL PRODUCTS

VOLTAGE REJECT

There is a red jumper on two pins of a three-pin base labeled Voltage Reject (SW3) on the left-hand side of the board. The red two pin jumper comes from the factory installed on the left hand and center pins. With the jumper in the factory position, the board will accept triggers of any voltage equal to or greater than 24 Volts AC / DC (but not exceeding 240 Volts AC / DC). If you would like the board to disregard triggers from the machine

with a voltage of less than 75 Volts AC / DC, pull the red jumper off and place it on the center and right-hand pins.

TUBING

Measure and cut a piece of supply tubing to go between the dip tube and the intake (left) side of the pump(s). Use the compression nuts provided to secure the tubing. Measure and cut a piece of supply tubing to go between the output (right) side of the pump(s) and the laundry machine. Use the compression nut on the output side of the pump(s) to secure the line.

DELAY TIMES

Each circuit board for this system has a delay potentiometer on the upper right-hand side of the board, which provides an adjustable delay of up to 180 seconds.

TRIGGER VALIDATION SELECT - 5 TO 25 SECONDS

All of the boards have a red jumper on two pins of a three-pin base (Labeled SW4) above the three-position switch. The red two pin jumper comes from the factory installed on the right hand and center pins. With the red jumper in the factory position, the board will accept triggers that are present for a minimum of 5 seconds. Remember that if a valid trigger is recognized by the board, the green LED in the center of the board will light for as long as a valid trigger is present. If you would like a 25 second validation period, remove the red jumper and place it on the left hand and center pins. Now, a trigger will have to be active for 25 seconds to start a pump run (after any delay that might be set).

RUN TIMES

The pumps produce approximately 18 ounces per minute of water with ¼" tubing and 120 RPM motor. The output will be reduced by the viscosity of each product, temperature, and other factors. Always calibrate your pumps to determine how many ounces per minute of each product you can expect, and then set your run times according to what you need. There are two potentiometers for run time control. They are in the center of the board, near the top, and marked underneath each. The bottom potentiometer controls a run time of 0 - 180 seconds. The top potentiometer controls a run time of 0 - 25 seconds. For longer run times, use the bottom potentiometer and fine-tune the run time with the 0 - 25-second control.

Motor	Tube	Output per minute
120 RPM (2885)	3/8"	~24 oz.
30 RPM (2882)	¼"	~ 4 oz.
30 RPM (2882)	3/8"	~ 6 oz.

SETUP - PRIMING - CHECKING RUN TIME WITHOUT A TRIGGER

The three-position switch on the bottom right hand corner of each board controls the main functions you need during the installation.

Left Hand Position - Pump priming. The pump will prime if the switch is in this position.

Center Position - Run. Once the installation is complete, run times have been checked, and you are ready to leave, **THE SWITCH MUST BE IN THE CENTER POSITION TO OPERATE**. It will recognize a trigger and run the pump in this position.

Right Position - Verify run time and delay. This position will allow you to verify, by quantity or time, what run time you have each pump set for. Move the switch to the right-hand position and either time the pump run or hold a measuring cup under the correct pump. Any delay will be active and time out. Once the run is complete, **MOVE THE SWITCH BACK TO THE CENTER POSITION**. If the run time needs to be adjusted, do it now. Once the adjustment has been made, move the switch to the timed position to verify the new run time.

BEFORE LEAVING THE INSTALLATION:

1. Make sure that all the three position switches are in the center position and that the green trigger indicator lights in the center of each board are off.
2. Verify that the power switch is in the on position by checking the power indicator light on the front of the lid.
3. Run a load in the washing machine to verify that everything has been hooked up properly, i.e. trigger(s) are indicated by green light, pump(s) run, and that they run in the correct order.

WARRANTY

Viking LLC, A DEMA Company products are warranted against defective material and workmanship under normal use and service for one year from the date of manufacture. This limited warranty does not apply to any products which have a normal life shorter than one year or failure and damage caused by chemicals, corrosion, improper voltage supply, physical abuse or misapplication. Rubber and synthetic rubber parts such as "O" rings, diaphragms, squeeze tubing and gaskets are considered expendable and are not covered under warranty. This warranty is extended only to the original buyer of Viking LLC products. If the products are altered or repaired without prior approval of Viking LLC, this warranty will be void.

Defective units or parts should be returned to the factory with transportation prepaid. If inspection shows them to be defective, they will be repaired or replaced without charge, F.O.B. factory. Viking LLC assumes no liability for damages. Return Merchandise Authorization (RMA) number to return units for repair or replacement must be granted in advance of return.

Pro Laundry Board

Main Board = 2030, Secondary = 2032

Power LED

Delay 0-180 seconds

Run time (FINE) 0-25 seconds

Run time (COARSE) 0-180 seconds

Trigger Validation*

Voltage Reject*

***Voltage Reject:** Factory setting on 24 volts AC/DC, can place jumper to reject less than 75 volts AC/DC

***Trigger Validation:** Factory setting 5 seconds, can place jumper to validation of 25 seconds

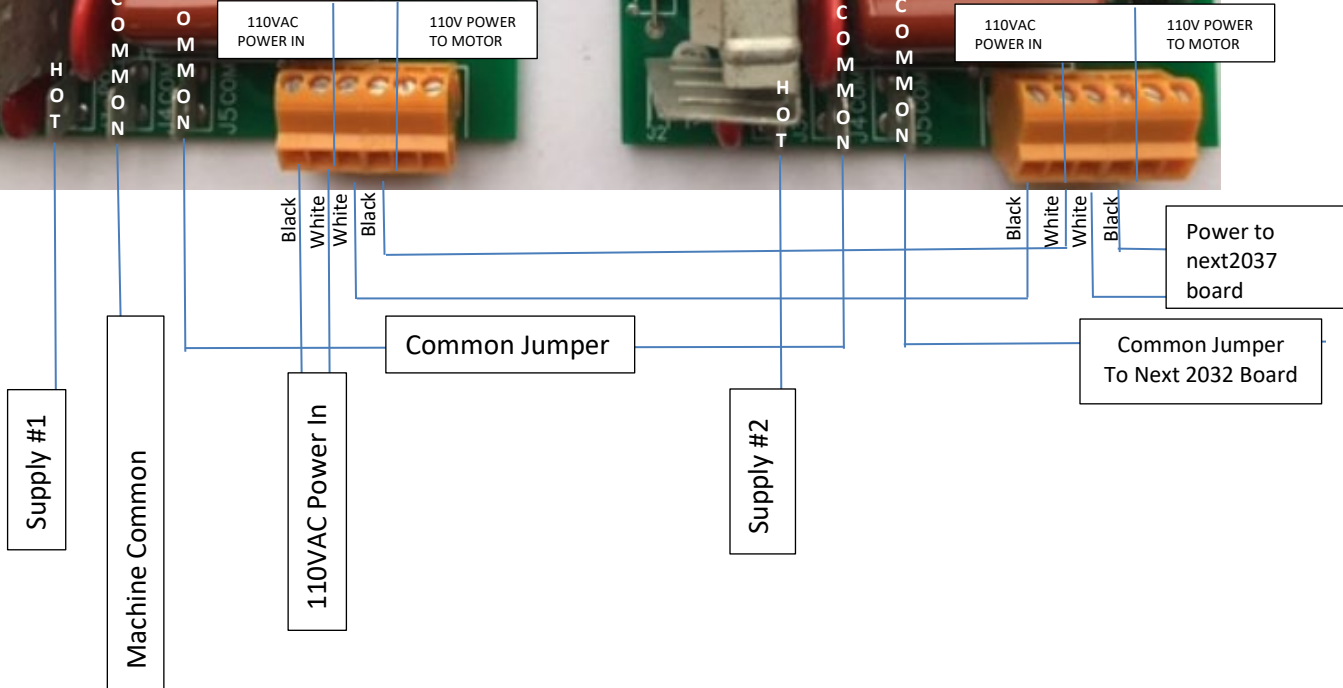
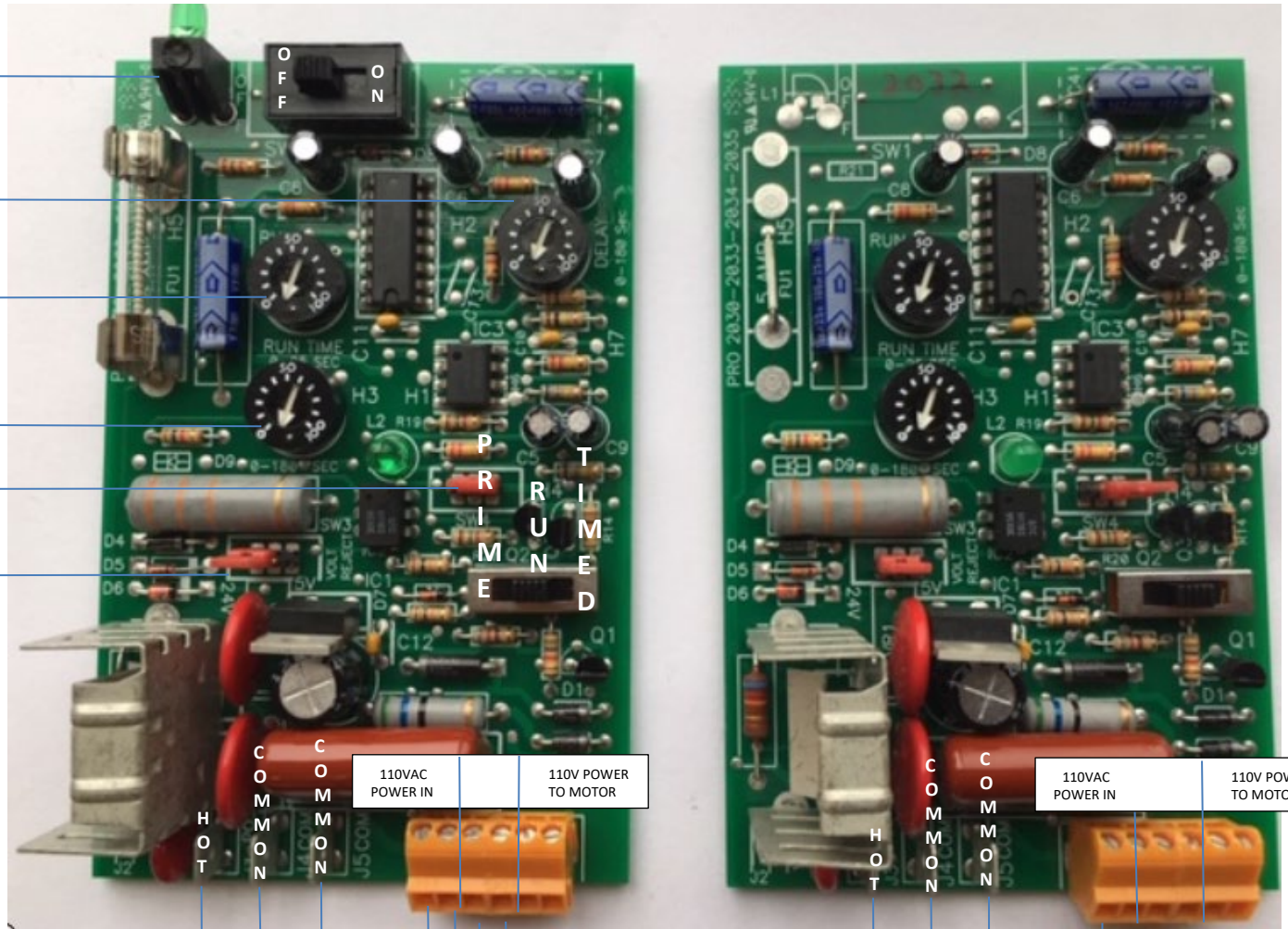
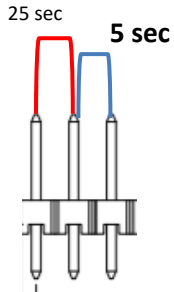
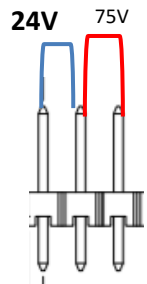

110VAC POWER IN 110V POWER TO MOTOR

110VAC POWER IN 110V POWER TO MOTOR

Supply #1

Machine Common

110VAC Power In

Common Jumper

Supply #2

Common Jumper To Next 2032 Board

Power to next2037 board