

Viking Drain & Odor Control System

Dispensing Systems For Grease-Digesting Chemicals (Bacteria, Enzyme, Solvent) & Odor Suppression Chemicals



Visit Us Online At www.thevikingbowl.com



DC model shown with EZ connect battery pack

Drain Chief Plus

Control System for Dispensing Grease-Digesting Chemicals or Enzymes

Viking is leading the industry with field-proven drain and odor control chemical dispensing systems. Viking's Drain & Odor Control Systems are known for their reliability and durability in the field. They are backed by a solid one-year warranty. The Viking Drain Chief Plus combines all the required features of our existing drain and odor control products with advanced, yet easy to use features such as, a digital programming display, multiple chemical pump options, quick change pumps and a quick service battery pack with low battery alerts. Drain Chief Plus is easily adaptable for odor suppression and deodorizing needs, with a quick programming change and a part swap, known as the Scentnal Plus.

Common Applications

Grease traps, drain maintenance, odor control, dumpster, trash chutes, food service, lodging, food processing, lift stations, call for feasibility of other applications.

Scentnal Plus Spray Version Available

- Odor Control for Trash chutes and Dumpsters
- Squeeze tubes available; EPDM, Supertube (PVC) and Viton

Features & Benefits

- Common sense, easy to understand and digital programming
- 24/7 battery monitor with low battery warning
- Water resistant components for under counter and low wall installations
- "Plug-n-go" electrical hookup for quick and easy connect/disconnect
- Tool less quick change pump
- Fast snap mounting bracket to quickly remove/reattach unit from wall for preventative maintenance
- Easy switch between odor suppression & drain maintenance modes through simple programming
- Odor suppression mode uses a brass nozzle with configurable spray pattern for stream to mist adjustments

Fittings Available

- Plastic Compression fitting for simple drain pipe connection
- Brass spray nozzle for odor control- Adjustable stream to mist; Can be bulkhead/bracket mounted

Drain Chief Plus can be ordered with the following configurations:

- Drain or Odor Control
- AC wall power (115/230VAC) or Battery Power
- Three different squeeze tube choices:

Squeeze Tube

E = EPDM Squeeze Tube

P = Supertube (PVC Squeeze Tube)

V = Viton Squeeze Tube

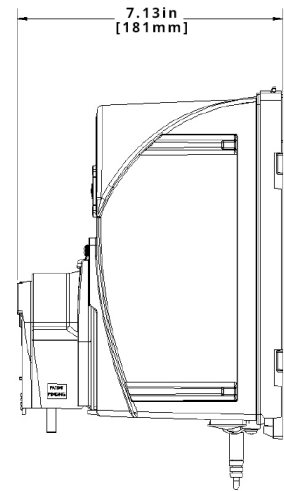
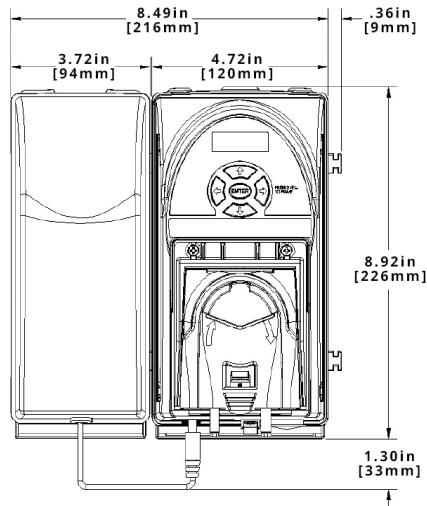

Battery Connection



Brass Spray nozzle
* Available with
Scental Plus only



Plastic Compression fitting
* Available with
Drain Chief Plus only

SPECIFICATIONS		
Main Power	12VDC - 2.0A min from 8 x D-cell batteries or 115 VAC or 100-240 VAC wall adapters	
Motor/Solenoid Rating	12 VDC - 1.25A max.	
Enclosure Material	ABS	
Shipping Wt. (AC)	5.0 lbs	2.3 kg
Shipping Wt. (Battery)	6.1 lbs	2.8 kg
Installed Wt. (AC)	2.7 lbs	1.3 kg
(w/ batteries)	3.4 lbs	1.6 kg



Drain Chief Plus



Viking

512 Industrial Road
Nesquehoning, PA 18240

Tel: 800.441.1343
570.645.3633
Fax: 570.645.3679



www.thevikingbowl.com



sales@thevikingbowl.com